



# DK20 SERIES

## Specifications

MODEL	DK4520	DK5020	DK5520
<b>ENGINE</b>			
Engine Gross HP (KW)	44.9 (33.5)	50.3 (37.5)	55 (41)
PTO HP (KW)	38.9 (29.0)	41.5 (31.0)	46.4 (34.6)
Displacement cu. in. (cc)	111.4 (1,826)		
Rated Revolution	2,600 rpm		
Fuel Tank Capacity	11.9 gal. (45 ℓ)		
<b>DRIVE TRAIN</b>			
Clutch	Dry Single Stage		
Transmission	Synchronized Shuttle		
Speeds	8F/8R		
Differential Lock	Rear Standard		
Brake	Wet Disc Type		
PTO	Independent		
Rear PTO (Standard)	540 rpm		
Mid PTO (Optional)	N/A		
4WD Type	Manual		
<b>HYDRAULIC SYSTEM</b>			
Pump	Gear		
Pump Capacity (Max flow rate)	14.56 gpm (55.1 ℓpm)		
3-Point Hitch	Category I		Category II
Maximum Lifting Capacity*	2,716 lbs. (1,232 kg)		
Hydraulic Lift Control System	Position		
No. of Standard Remote Valves	(2 Optional)		
Steering	Hydraulic Power Steering		
<b>TIRE SIZE</b>			
Front AG. (Turf, Industrial)	8-16 (29-12.5-15, 10-16.5)		
Rear AG. (Turf, Industrial)	13.6-24 (21.5L-16.1, 14.9-24)		
<b>TRAVELING SPEEDS</b>			
Forward mph (kph)	1.29-16.71 (2.08-26.9)		
Reverse mph (kph)	1.26-16.28 (2.03-26.2)		
<b>DIMENSIONS</b>			
Overall Length (incl. 3-pt hitch)	124.3 in. (3,157 mm)		
Overall Width (min. tread)	62.8 in. (1,596 mm)		
Overall Height	96.8 in. (2,458 mm)		
Wheelbase	71.3 in. (1,810mm)		
Min. Ground Clearance	14.5 in. (368 mm)		
Tread	Front (AG)	49.4 in. (1,254 mm)	
	Rear (AG)	49.3 in. (1,251 mm)	
Min. Turning Radius (w/brake)	8.56 ft. (2.6 m)		
Weight w/AG. Tires lbs. (kg)	3,373 (1,530)		

\*(24" aft. of hitch)

NOTE: Specifications and design are subject to change without notice.

### STANDARD EQUIPMENT

- Power Steering
- Rear PTO
- Wet Multi Disc Brakes
- Drawbar
- Headlights
- Parking Brake
- PTO Shield

### OPTIONAL EQUIPMENT

- Front Weights
- Deck Mat
- Clevis Type Drawbar
- Side View Mirror (1 ea / ROPS Only)
- Fuel Heater Kit
- Single Remote Hydraulic Valve (Spring/Detent)
- 2nd Remote Hydraulic Valve (Spring/Detent)
- Rear Wheel Weight (Ag & Ind Tires Only)
- 3rd Function Kit for Loader
- Bluetooth Speaker Kit
- RPM Increase Kit for Loader

### ATTACHMENTS

- Front End Loader
- Backhoe
- Contact your local KIOTI dealer for available implements and attachments.



# DK20 SERIES

## Specifications

### Front End Loader

The KIOTI KL5520 and KL5521 front end loaders are specifically designed for the DK20 Series tractors, providing efficient performance with single lever joystick control and a quick attach bucket. The loader, with a built-in parking stand, is designed to be quickly and easily attached and detached. KL Series loaders utilize the tractor's hydraulic system, feature single-lever control with float and come with a bucket level indicator.

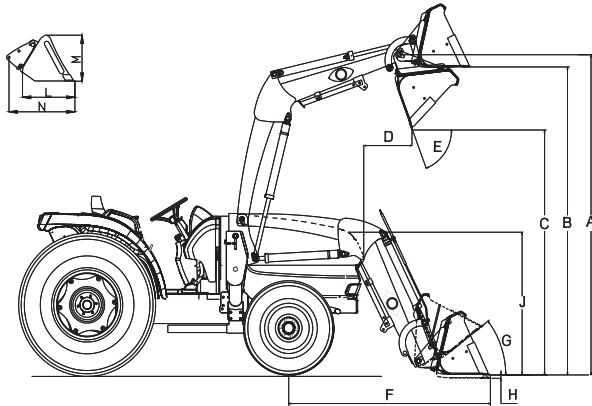

MODEL	KL5520 / KL5521
A Maximum Lift Height to Pivot Pin	107.7 in. (2,735 mm)
B Clearance w/ Bucket Level	96.3 in. (2,446 mm)
C Clearance w/ Bucket Dumped	78.8 in. (2,001 mm)
D Reach at Maximum Height (45°)	22.7 in. (576 mm)
E Maximum Dump Angle	46°
F Reach w/ Bucket on Ground	71.1 in. (1806 mm)
G Maximum Rollback Angle	41°
H Digging Depth Below Grade	8.6 in. (218 mm)
J Overall Height in Carry Position	54 in. (1371 mm)
L Bucket Depth (Inner Shell)	18.5 in. (470 mm)
M Bucket Height	22 in. (560 mm)
N Bucket Length (Pivot Pin)	26 in. (660 mm)
Lift Capacity at 59.84 in. (1,520 mm) Pivot Pin Height	2,474 lbs. (1,122 kg)
Breakout Force at Pivot Pins	3,895 lbs. (1,767 kg)
Relief Valve Setting (Loader Control Valve)	2,273 psi (195 kg/cm <sup>2</sup> )
Rated Flow (Tractor System)	4.2 gpm (16 L/min)
Bucket Size(s) Available (QA)	66 in. / 72 in.
Approximate Weight (With Bucket)	66 in.: 946 lbs. (429 kg) / 72 in.: 1,085 lbs. (492 kg)
Bucket Capacity (Heaped)	66 in.: 13.4 cu. ft. / 72 in.: 15.5 cu. ft.
Bucket Rollback Force at Ground Line	3,148 lbs. (1,428 kg)
Single Lever Joystick	KL5520: Optional / KL5521 Standard
Compatible Models	KL5520: ROPS / KL5521 Cab

Cycle Times	2,600 rpm (Full)
Raise Boom Frame	3.9 sec
Lower Boom Frame	2.3 sec
Dump Bucket	3.2 sec
Retract Bucket	1.9 sec

\* Specifications and design are subject to change without notice.

### Backhoe

The KIOTI KB2485 backhoe lets you trench up to 94.4 inches deep with a bucket dig force up to 3,748 pounds. The KB2485 backhoe features subframe mounting, responsive two-lever controls with exceptional feathering, hydraulic stabilizers, transport lock and a variety of standard and heavy-duty buckets.

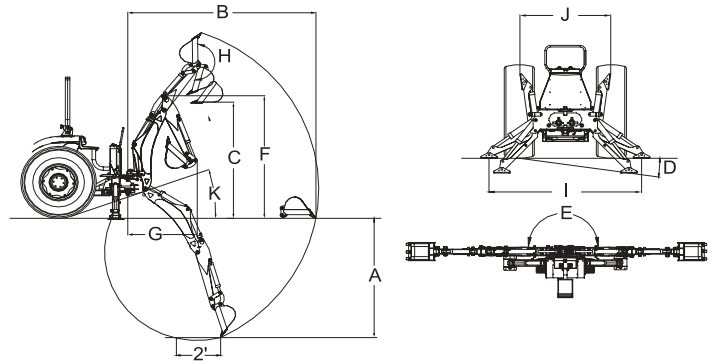

MODEL	KB2485
A Digging Depth (Two Foot Flat Bottom)	94.4 in. (2,400 mm)
B Reach from Center Line of Swing Pivot	136.1 in. (3,460 mm)
C Loading Height (Bucket at 60°)	80.3 in. (2,040 mm)
D Maximum Leveling Angle	10°
E Swing Arc	180°
F Transport Height (Maximum)	92.9 in. (2,360 mm)
G Transport Overhang	50.4 in. (1,280 mm)
H Bucket Rotation	180°
I Stabilizer Spread (Down Position)	68.7 in. (1,745 mm)
J Stabilizer Spread (Up Position)	46.4 in. (1,180 mm)
K Angle of Departure	21°
Shipping Weight (Without Bucket)	1,102 lbs. (500 kg)
Bucket Digging Force	3,748 lbs. (1,700 kg)
Dipperstick Digging Force	2,205 lbs. (1,000 kg)
Operating Pressure	2,466 psi (170 bar)

### Cylinders

Cylinder	Bore DIA	Retracted Length	Stroke	Rod DIA
Boom	2.75	25.04	15.20	1.57
Bucket	2.36	24.8	15.55	1.38
Dipperstick	2.75	27.87	19.88	1.57
Swing	2.36	15.67	8.78	1.38
Stabilizer	2.36	17.55	10.31	1.38

### Buckets

Bucket	Teeth Quantity	Struck Capacity	Heaped Capacity	Shipping Weight
12" Bucket	3	1.01 cu. ft.	1.24 cu. ft.	56 lbs.
18" Bucket	4	1.56 cu. ft.	2.02 cu. ft.	70 lbs.
24" Bucket	5	2.11 cu. ft.	2.82 cu. ft.	94 lbs.
36" Bucket	6	2.78 cu. ft.	4.00 cu. ft.	114 lbs.

\* Specifications and design are subject to change without notice.